

SPECIFICATIONS	
HOUSING MATERIAL	DIE-CAST ALUMINUM ALLOY
HOUSING FINISH/COLOR	POWDER COAT/BLACK
RECEPTACLE HOUSINGS	316 STAINLESS STEEL/PASSIVATED
GLAND MATERIAL	NYLON
CONTACT CARRIERS/COLOR	NYLON/BLACK
CONTACTS	GOLD-PLATED BRASS
OPERATING VOLTAGE	250 VAC/300 VDC
OPERATING CURRENT	4.0 AMPS PER PORT, 8.0 AMPS TOTAL
OUTER JACKET MATERIAL/COLOR	PVC/BLUE
CONDUCTOR INSULATION MATERIAL	PVC
CONDUCTORS	16x22 AWG, 1x18 AWG GROUND
DRAIN/SHIELD	9x22 AWG DRAINS/ALUMINUM FOIL SHIELDED
PROTECTION CLASS	MEETS NEMA 1,3,4,4X,6P,12 AND IEC IP67,IP68,IP69,IP69K
OPERATING TEMPERATURE	-40°C to +80°C (-40°F to +176°F)
CONDUCTOR ARRANGEMENT	8 STP W/ DRAIN, 1 GND, 1 DRN
CABLE RATINGS	UL: ITC/PLTC/AWM, 105°C, 300 V CSA: CMG/AWM, 105°C, 300 V

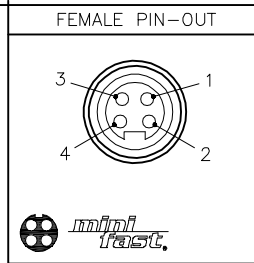

CABLE LENGTH	TOLERANCE *
ALL LENGTHS	+ 4% (OR 50mm) OF LENGTH - 0% (OR 0mm) OF LENGTH WHICHEVER IS GREATER
STRIP LENGTH	TOLERANCE *
0-7mm	±0.5mm
8-29mm	±1.0mm
30-49mm	±2.0mm
50-69mm	±3.0mm
70-100mm	±4.0mm
OVER 100mm	±5.0mm

* UNLESS OTHERWISE SPECIFIED

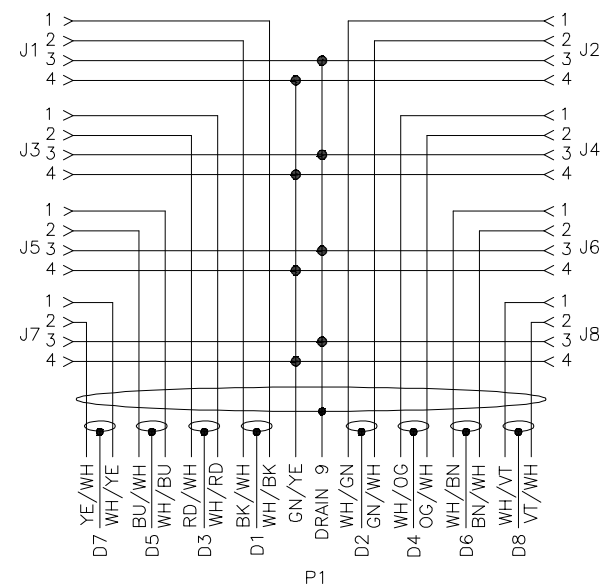
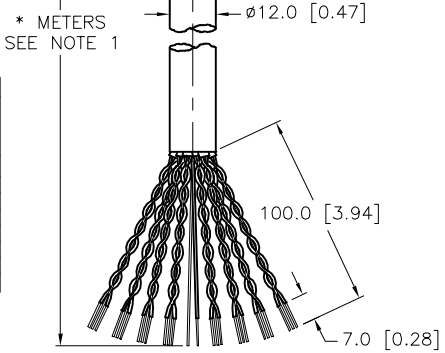

- NOTES:
- "*" INDICATES CABLE LENGTH IN METERS. CONTACT TURCK TO ORDER SPECIFIC LENGTHS.
 - CLEARANCE HOLE FOR M4 [#8] MOUNTING SCREWS (2 NOT INCLUDED).

RELATED DOCUMENTS	3RD ANGLE PROJECTION	THIS DRAWING IS CONFIDENTIAL AND THE PROPERTY OF TURCK INC. USE OF THIS DOCUMENT WITHOUT WRITTEN PERMISSION IS PROHIBITED.		3000 CAMPUS DRIVE MINNEAPOLIS, MN 55441 1-800-544-7769 (763) 553-7300 (763) 553-0708 fax www.turck.us	
1. 2. 3. 4.		DRFT	TH	DATE	06/03/05
MATERIAL	SEE SPECIFICATIONS	APVD	TH	SCALE	1=2.0
FINISH	SEE SPECIFICATIONS	UNIT OF MEASUREMENT		DESCRIPTION	
	CONTACT TURCK FOR MORE INFORMATION	MILLIMETER [INCH]		P-8 RKV 40-977-*	
		DO NOT SCALE THIS DRAWING		IDENTIFICATION NO.	REV
				FILE: 777011399	D
				SHEET 1 OF 1	